

uniLIGHT.at Winch SMALL & MEDIUM

Our towing winches SMALL and MEDIUM are a new milestone for the F-tow in model flying. With the winches, it is now possible to catch up with the tow rope completely automatically after the release of the glider and to safely fly and land with figures on the descent. The intelligently controlled automatic retractor allows numerous possibilities for beginners and professionals. The functionality, electronics and software of the winches are identical, it only differs the installation situation and the size in the model.

SMALL optimized for minimum size, ideal for electric operation and sailors up to 12–15kg

MEDIUM was built as a robust standard version and can tow gliders up to 25kg

The winches consist of CNC manufactured aluminum parts and milled fiber composite panels. This allows us to achieve the lowest weight with maximum strength. The drive is a light, brushless motor with a non-blocking belt drive. The motor output stage, the entire control electronics and also the servo for emergency shedding are already integrated. Each winch is accompanied by a high-performance uniLIGHT.at flashlight, with which the operating status can still be seen from the ground.

Each winch is configurable via the **uniLIGHT PLUS** interface and our software*

Features and functions

- Winch mechanics aluminum fiber composite
- Block-free belt slip drive
- Cable guide made of bearing nylon
- integrated brushless drive
- Power stage integrated, brushless
- emergency release / servo integrated
- Integrated control electronics
- Output for signal light uniLIGHT
- Automatic overload monitoring
- Automatic shock absorption*
- Rotation detection for shutdown
- Brake function in de-energized state
- Electronics area closed
- Magnetic kinematics detection
- Automatic rope length calibration*
- Intelligent dynamic rope tension*
- Variable winding speed
- take-up limit remaining length*
- Automatic residual winding shutdown*
- Intelligent emergency release integrated*
- Multiple function via a servo channel
- programmable via **uniLIGHT PLUS**

Connections and signals

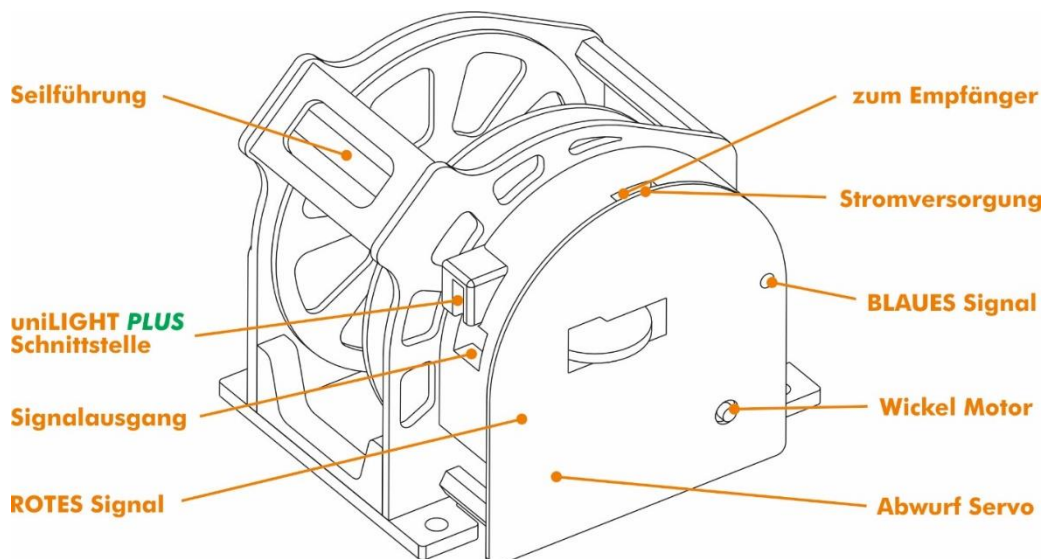

* depending on the firmware version

Cable guide the tow must be guided through the guide to the spool to allow knot-free winding. Depending on the winding speed, sufficient aerodynamic braking effect should be present

uniLIGHT PLUS Data interface for advanced configuration and update of the winch

Signal output Connection for a uniLIGHT Power Strobe light for external representation of the RED signal. This signal provides information about the condition of the winch

0-1-0	short: winch in tow mode, no action
0-111-0	long: winch in dynamic towing mode, increased energy requirement*
0-101-0	2x short: Winch in slow winding mode
0-10101-0	3x short: winch in medium winding operation
0-1010101-0	4x short: Winch in fast winding mode
0-1-0-111-0	short-long: wrapping completed
0101010101	flashing: emergency release

BLUE signal provides information about the signal from the receiver. If there is no signal or if the signal is outside the usable range, this light flashes

Winding engine Brushless electric motor with belt drive to the coil. Make sure that the motor can rotate freely. Pay attention to the direction of rotation under the item "Installation position"

Shedding servo integrated high-performance servo for emergency release of the tow rope (full metal, 95Ncm)

Functionality

1. Plug the 2-pin JST power cable into a 2S LiPo battery
2. Then connect the 3-pin servo cable to the receiver and switch on your reception system. Make sure that the servo position is approximately in the middle position. There should be several beeps with a small and then two beeps with a longer distance audible.
3. Depending on how the servo position is changed, different functions of the winch are activated. Configure your transmitter to ensure easy and reliable selection of functions; in particular, the emergency shedding must be quick and safe, but not accidentally reachable. Depending on the manufacturer of the transmitter, this can be implemented flexibly and elegantly via encoder settings and mixers.

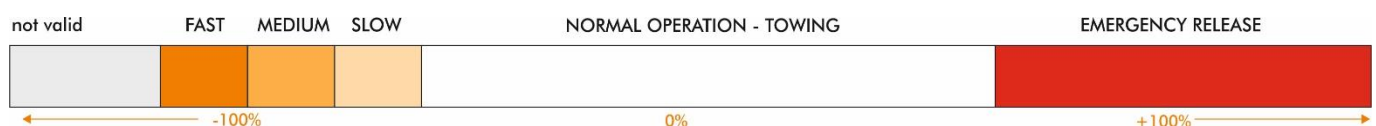

Winding speed As soon as the functions can be selected from the transmitter, please make sure that you have the correct, selected winding speed. Also pay attention to the flashing signals of the RED LED in the housing or the external power LED. Note that slow winding will result in a better bump and fewer knots.

Hooking in the rope To hook in a new rope, turn the spool so that the notch for the rope lock is easily accessible. Then guide the rope through the hull entry first and then through the cable guide of the

* depending on the firmware version

winch. Depending on the installation position and skill, you can now lock the rope immediately by setting the switch position back to normal or 0%, the locking pin will close slowly to allow some time for positioning. Then check that the rope is securely locked.

Winding up To wind the rope, bring the servo position into the -75% range until the winding process starts slowly. If you are not in the air, hold the rope back slightly to simulate the aerodynamic braking effect. When the stop (ball or similar) is reached, the electronics of the winch will recognize this by the absence of rotation of the coil and the increased blocking current. Depending on how much was wound, the automatic tries to repeat the process a few times to be safe in the end position.

If the servo position is not returned to normal operation, the automatic will respond to any attempt to unroll the rope.

Installation of the cable guide

The winch itself can be noted on the fuselage bottom or a carrying bulkhead, the cable guide, however, must be mounted cleanly above the winch in the back of the fuselage (there were already successful implementations with "tail drag" as in the original models).

Make sure that even here very high forces can arise during towing and look for a correspondingly massive spot. Also, make sure that a rope dropped in an emergency can whip at high voltage – there should be no systemically important components in the possible impact area.

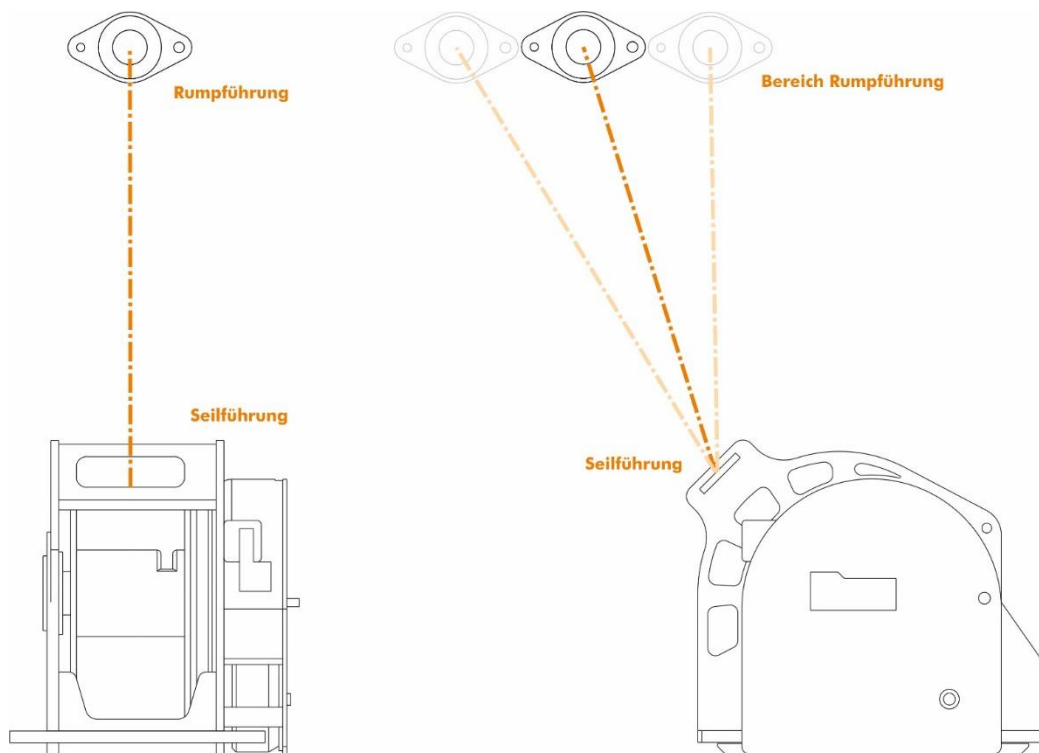

Figure 1: be sure to mount the bushing exactly above the winch along the vertical axis of the model. If the pulling forces are not introduced straight into the mounting points, damage to the axles, bearings and housings can easily occur.

Figure 2: Along the vertical axis, the hull infeed can be set flexibly. Just make sure that the rope always runs over the brass axles and does not rub permanently on a fiberboard. The straighter the introduction, the more reliable the winding process will be.

Care and wear

The belt drive is a simple and safe type of drive, in which there can be no jamming. However, this belt is a wearing part and must be changed according to use. To do this, open the screws on the back of the winch and remove the coil. Operating mode "Dynamic" significantly increases wear.

Likewise, the nylon guides of the fuselage insertion are designed as wearing parts. If there are clear grooves, then please change the nylon bushing.

For emergency release, a 2mm steel pin is moved via an eccentric drive. The spool turns around this pin. Due to the realization of this release pin is free in the guide and can cause slight rattling when winding up. You can lubricate this pin from the winch back over the hollow shaft.

Installation position in the model

The tow winch can be mounted horizontally on the hull bottom or vertically on a supporting bulkhead. This is basically indifferent to the function. It only has to be ensured that the winding direction is selected correctly for the corresponding installation position. If the preset orientation is not correct, then this can be changed via the **uniLIGHT PLUS** interface, or two lines of the motor can be crossed out.

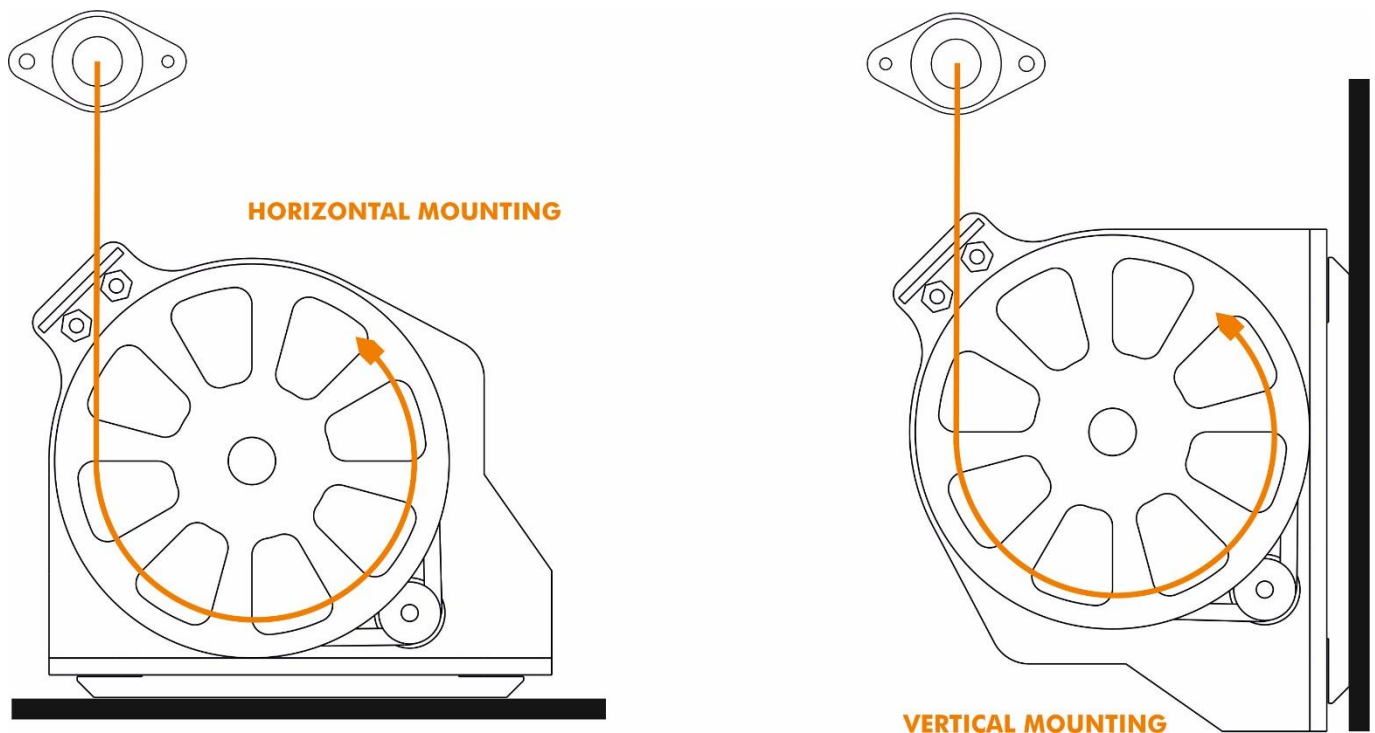

Technical Data

	SMALL	MEDIUM
Control side receiver:	3,6–9,6V	4,8–9,6V
Operating voltage winch:	8V/2S LiPo	8V/2S LiPo
Additional weight to the conventional system:	ca. 80g	ca. 160g
Dimensions:	45x89x79mm	62x92x84mm
Power consumption:	15–20mAh per tow plow	20–25mAh per tow plow
Control:	1x PPM	1x PPM
Galvanically isolated system:	YES	YES
Master / Slave shutdown system:	–	YES
Winding space:	ca. 30m/0.8mm rope ca. 25m/1.0mm rope	>40m/0.8mm rope ca. 35m/1.0mm rope ca. 30m/1.3mm rope ca. 25m/1.5mm rope
Rope:	–	–
Through hull:	included	included
Amplifier frame:	–	YES
Overload:	*	*
Discharge protection:	*	*
Total weight:	154g	235g
uniLIGHT Signal light:	RND-080	PRO16F-080x2

Further information can be found on www.unilight.at